

Probing Mechanical Vibrations in 2D Materials: A Michelson Interferometer Approach

CNF Summer Student: Amelie Deshazer

**Student Affiliation: Materials Science and Engineering,
University of Wisconsin Madison**

Summer Program(s): 2024 Global Quantum Leap International Research Training Experiences (GQL IRTE) Program at the National Institute for Materials Science (NIMS), Tsukuba, Ibaraki, Japan

Principal Investigator(s): Dr. Ryo Kitaura, National Institute of Materials Science (NIMS), Tsukuba, Japan

Mentor(s): Dr. Daichi Kozawa, National Institute of Materials Science (NIMS), Tsukuba, Japan

Primary Source(s) of Research Funding: NSF GQL IRTE Grant to University of Minnesota No. OISE-2020174

Contact: deshazaf@gmail.com, kozawa.daichi@nims.go.jp, kitaura.ryo@nims.go.jp

Summer Program Website: <https://cnf.cornell.edu/education/reu/2024>

Abstract:

Two-dimensional (2D) materials have gained attention in recent research due to their unique electrical, mechanical, and optical properties, making them promising candidates for future applications in semiconductors and quantum technologies. However, the intrinsic properties of 2D materials require sensitive instruments for accurate measurement and analysis. One such instrument is an interferometer, which measures interference patterns generated by wave interactions. This paper provides an overview of the interferometer's design, construction, and testing to ensure accurate interference detection. This research aims to utilize the interferometer to measure the mechanical vibrations of 2D materials suspended on membranes.

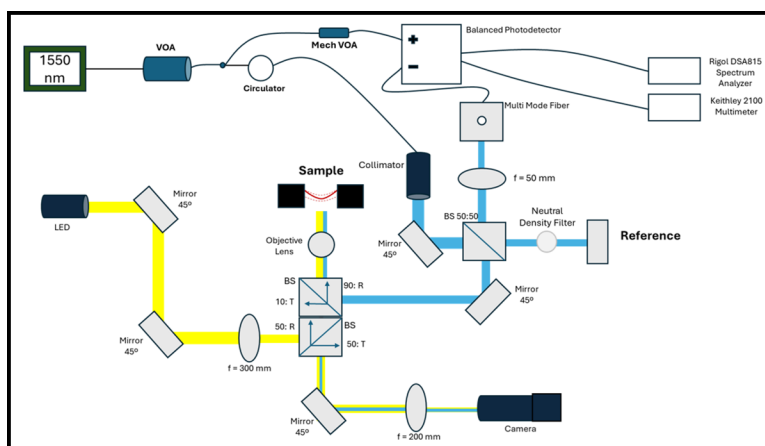

Figure 1: System block diagram of the interferometer.

Summary of Research:

Optomechanics. Optomechanics is a field that examines the interaction between electromagnetic waves and the motion of mechanical resonators. This interaction is studied using a setup where a beamsplitter directs laser beams of different wavelengths onto an oscillator. The radiation force from the lasers creates motion in the oscillator, which generates an interference pattern that is then detected. In linear mechanics, this signal typically produces a single symmetric peak.

This research focuses on nonlinear mechanics characterized by nonsymmetric and multiple peak vibrations. This behavior arises from Brownian motion in 2D materials, where atoms easily oscillate due to external factors. The sensitive nature of these fluctuations requires using an interferometer to accurately study and measure the nonlinear properties of 2D materials.

Building the System. An interferometer was constructed using a Michelson interferometer design, with a primary focus on reflection. Figure 1 presents a system diagram detailing the component configuration.

In this setup, a 1550 nm laser is directed toward the reference arm and the sample. The light reflected from these components interferes at the 50:50 beamsplitter, and the resulting interference pattern is transmitted through a multi-mode fiber to a balanced photodetector. The signal is then output to a spectrum analyzer. An LED is incorporated into the design to illuminate the sample, with the reflected light captured by a Thorlabs CS165MU camera.

The balanced photodetector is crucial for minimizing noise in the system. Given the system's sensitivity, reducing noise from both the sample and reference is essential. The photodetector achieves this by subtracting the - Input from the + Input, which requires the power levels of both inputs to be closely matched. A mechanical variable attenuator is employed to manually adjust the power delivered by the 1550 nm laser.

Automation. The second phase of building the measurement system involved automating the instruments to facilitate data acquisition by developing a graphical user interface

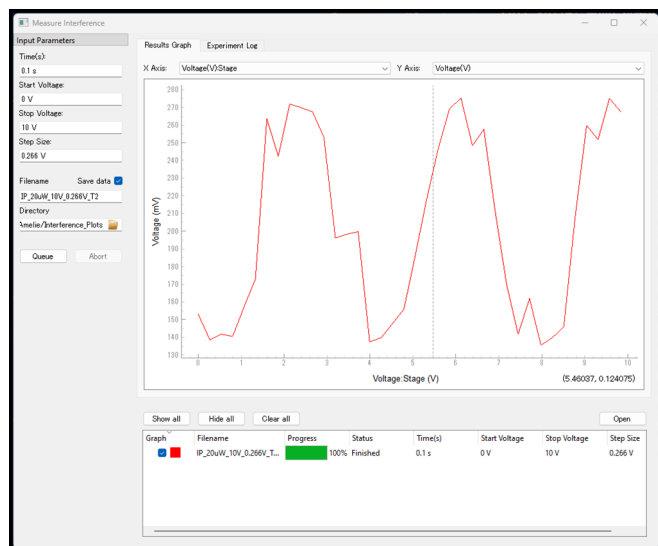

Figure 2: Graphical User Interface (GUI) displaying the interference measurement setup.

(GUI). This was achieved using Python's Pymouse library. Four instruments were automated: the Rigol DSA815, Thorlabs CS165MU, KPZ101 Piezo stage, and Keithley 2100 Multimeter. Each instrument was programmed into two distinct code blocks: the driver and the procedure. The driver code consisted of command blocks that enabled communication with the respective instrument, while the procedure code generated the GUI by calling the driver to control the device.

Figure 2 illustrates the GUI successfully implemented for two instruments: the KPZ101 Piezo stage and the Keithley 2100 Multimeter. In this setup, the Keithley 2100 measures voltage while the KPZ101 moves the reference arm.

Measuring Interference. Now that a GUI has been successfully created for the measurement system, interference can be measured without samples. The first series of tests were conducted using DC measurements; a Keithley 2100 Multimeter and a KPZ101 Piezo stage were used to measure the interference. The measurement setup involved applying 0 to 10 V to move the KPZ101 stage, with a step size of 0.266 V between data points. As a result, Figure 3 shows the DC measurement for the fit data, where a power of $20 \mu\text{W}$ was measured at the sample. The interference fitting was based on the sine function equation:

$$X(V) = A * \sin(\omega V + \phi) + V_0$$

Noise is shown in the measurement, as illustrated in the graph; therefore, AC measurements were utilized to minimize the noise.

A 0 to 10 V setup was applied with a step size of 0.266 V. An SRS SR830 lock-in amplifier, Keithley 2100 Multimeter, and KPZ101 Piezo stage were used in the measurement process. The power for this measurement was $10 \mu\text{W}$ at the sample. Figure 4 shows the fitted data using the sine function. The signal voltage was halved as the power was reduced during

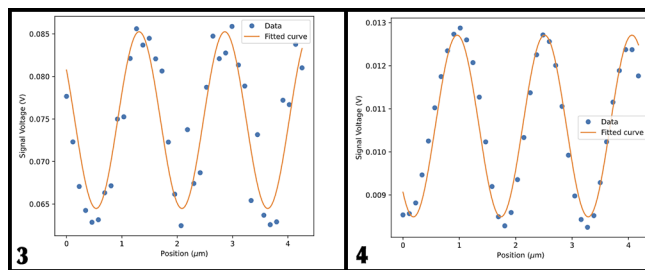

Figure 3, left: DC measurement of the interference pattern with no sample present. Figure 4, right: AC measurement of the interference pattern with no sample present.

this measurement, but the noise was minimized. The faint voltage signal is attributed to the power being reduced by half for the AC measurement.

Conclusions and Future Work:

To conclude, an interferometer was built using a 1550 nm laser while automating instruments to facilitate the measurement process. Testing the interference was achieved by employing DC and AC measurements. For this experiment, we successfully built an interferometer and tested interference while minimizing the noise. As a result, more work is needed to be done before testing the mechanical vibrations of 2D materials.

To ensure the interferometer works, frequency domain analyzer measurements are needed to confirm the accuracy of the spectrum analyzer. We need to verify with results that a peak at the center frequency is measured. Once this is confirmed, samples can be measured.

References:

- [1] H. Chang, J. Zhang, From cavity optomechanics to cavity-less exciton optomechanics: a review. *Nanoscale*, 14 (2022), pp. 16710-16730, DOI: 10.1039/D2NR03784J.
- [2] Xie, H.; Jiang, S.; Rhodes, D. A.; Hone, J. C.; Shan, J.; Mak, K. F. Tunable exciton-optomechanical coupling in suspended monolayer MoSe_2 . *Nano Lett.* 2021, 21, 2538-2543, DOI: 10.1021/acs.nanolett.0c05089.
- [3] Morell, N., et al.. Optomechanical Measurement of Thermal Transport in Two-Dimensional MoSe_2 Lattices. *Nano Lett.* 2019, 19, 3143-3150, DOI: 10.1021/acs.nanolett.9b00560.
- [4] G. Dion, S. Mejaouri, J. Sylvestre; Reservoir computing with a single delay-coupled non-linear mechanical oscillator. *J. Appl. Phys.* 21 October 2018; 124 (15): 152132, DOI: 10.1063/1.5038038.